

MMDL101T1

Schottky Barrier Diode

Schottky barrier diodes are designed primarily for high-efficiency UHF and VHF detector applications. Readily available to many other fast switching RF and digital applications.

- Very Low Capacitance — Less than 1.0 pF @ Zero Volts
- Low Noise Figure — 6.0 dB Typ @ 1.0 GHz
- Device Marking: 4M

MAXIMUM RATINGS

Symbol	Rating	Value	Unit
V_R	Reverse Voltage	7.0	Vdc

THERMAL CHARACTERISTICS

Symbol	Characteristic	Max	Unit
P_D	Total Device Dissipation FR-5 Board,*	200	mW
	$T_A = 25^\circ\text{C}$ Derate above 25°C	1.57	mW/ $^\circ\text{C}$
$R_{\theta JA}$	Thermal Resistance Junction to Ambient	635	$^\circ\text{C}/\text{W}$
T_J, T_{stg}	Junction and Storage Temperature Range	-55 to +150	$^\circ\text{C}$

*FR-5 Minimum Pad



ON Semiconductor™

<http://onsemi.com>

1.0 pF SCHOTTKY BARRIER DIODE

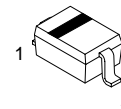

PLASTIC
SOD-323
CASE 477

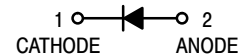

ORDERING INFORMATION

Device	Package	Shipping
MMDL101T1	SOD-323	3000 / Tape & Reel

ELECTRICAL CHARACTERISTICS ($T_A = 25^\circ\text{C}$ unless otherwise noted)

Characteristic	Symbol	Min	Typ	Max	Unit
Reverse Breakdown Voltage ($I_R = 10 \mu\text{A}$)	$V_{(BR)R}$	7.0	10	—	Volts
Diode Capacitance ($V_R = 0, f = 1.0 \text{ MHz}$, Note 1)	C_T	—	0.88	1.0	pF
Reverse Leakage ($V_R = 3.0 \text{ V}$)	I_R	—	20	250	nAdc
Noise Figure ($f = 1.0 \text{ GHz}$, Note 2)	NF	—	6.0	—	dB
Forward Voltage ($I_F = 10 \text{ mA}$)	V_F	—	0.5	0.6	Vdc

*Notes on Next Page

MMDL101T1

TYPICAL CHARACTERISTICS

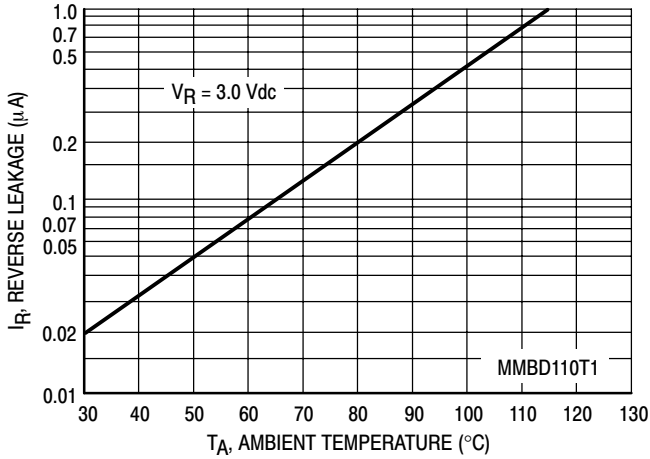

Figure 1. Reverse Leakage

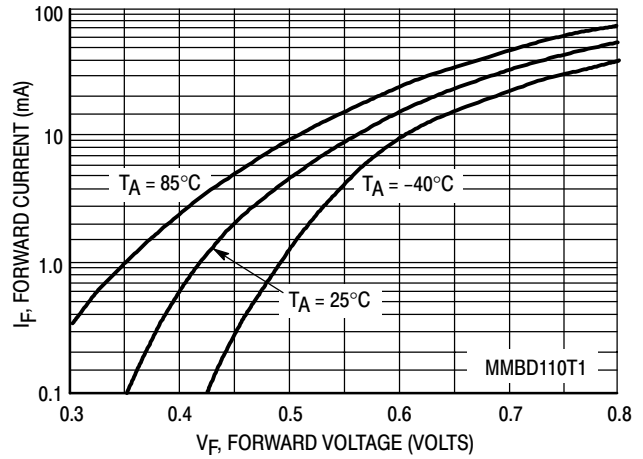

Figure 2. Forward Voltage

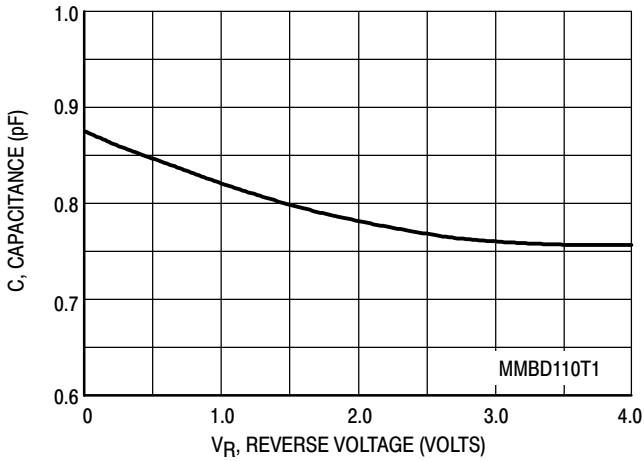

Figure 3. Capacitance

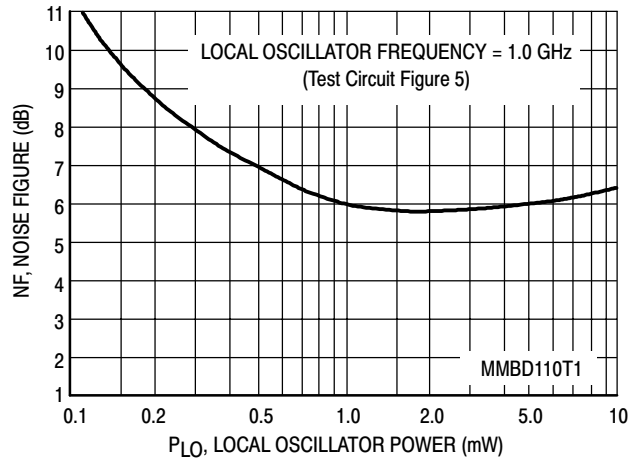

Figure 4. Noise Figure

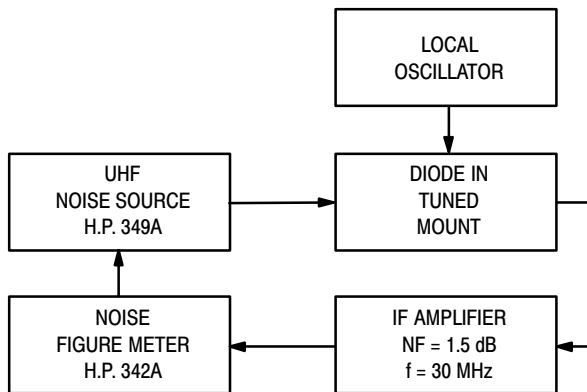

Figure 5. Noise Figure Test Circuit

NOTES ON TESTING AND SPECIFICATIONS

- Note 1 — C_C and C_T are measured using a capacitance bridge (Boonton Electronics Model 75A or equivalent).
- Note 2 — Noise figure measured with diode under test in tuned diode mount using UHF noise source and local oscillator (LO) frequency of 1.0 GHz. The LO power is adjusted for 1.0 mW. IF amplifier NF = 1.5 dB, $f = 30$ MHz, see Figure 5.

MMDL101T1

PACKAGE DIMENSIONS

SOD-323
 PLASTIC PACKAGE
 CASE 477-02
 ISSUE A

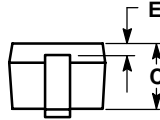
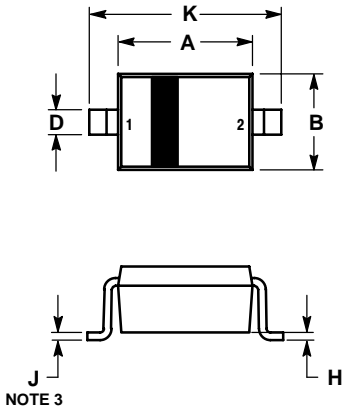

- NOTES:
1. DIMENSIONING AND TOLERANCING PER ANSI Y14.5M, 1982.
 2. CONTROLLING DIMENSION: MILLIMETERS.
 3. LEAD THICKNESS SPECIFIED PER L/F DRAWING WITH SOLDER PLATING.

DIM	MILLIMETERS		INCHES	
	MIN	MAX	MIN	MAX
A	1.60	1.80	0.063	0.071
B	1.15	1.35	0.045	0.053
C	0.80	1.00	0.031	0.039
D	0.25	0.40	0.010	0.016
E	0.15 REF		0.006 REF	
H	0.00	0.10	0.000	0.004
J	0.089	0.177	0.0035	0.0070
K	2.30	2.70	0.091	0.106

- STYLE 1:
 PIN 1. CATHODE
 2. ANODE

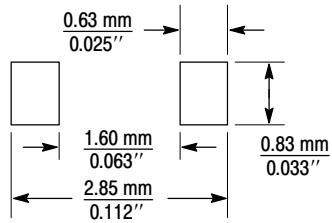

(mm / inches)

SOD-323
 Soldering Footprint

Thermal Clad is a trademark of the Bergquist Company.

ON Semiconductor and  are trademarks of Semiconductor Components Industries, LLC (SCILLC). SCILLC reserves the right to make changes without further notice to any products herein. SCILLC makes no warranty, representation or guarantee regarding the suitability of its products for any particular purpose, nor does SCILLC assume any liability arising out of the application or use of any product or circuit, and specifically disclaims any and all liability, including without limitation special, consequential or incidental damages. "Typical" parameters which may be provided in SCILLC data sheets and/or specifications can and do vary in different applications and actual performance may vary over time. All operating parameters, including "Typicals" must be validated for each customer application by customer's technical experts. SCILLC does not convey any license under its patent rights nor the rights of others. SCILLC products are not designed, intended, or authorized for use as components in systems intended for surgical implant into the body, or other applications intended to support or sustain life, or for any other application in which the failure of the SCILLC product could create a situation where personal injury or death may occur. Should Buyer purchase or use SCILLC products for any such unintended or unauthorized application, Buyer shall indemnify and hold SCILLC and its officers, employees, subsidiaries, affiliates, and distributors harmless against all claims, costs, damages, and expenses, and reasonable attorney fees arising out of, directly or indirectly, any claim of personal injury or death associated with such unintended or unauthorized use, even if such claim alleges that SCILLC was negligent regarding the design or manufacture of the part. SCILLC is an Equal Opportunity/Affirmative Action Employer.

PUBLICATION ORDERING INFORMATION

Literature Fulfillment:

Literature Distribution Center for ON Semiconductor
P.O. Box 5163, Denver, Colorado 80217 USA
Phone: 303-675-2175 or 800-344-3860 Toll Free USA/Canada
Fax: 303-675-2176 or 800-344-3867 Toll Free USA/Canada
Email: ONlit@hibbertco.com

N. American Technical Support: 800-282-9855 Toll Free USA/Canada

JAPAN: ON Semiconductor, Japan Customer Focus Center
4-32-1 Nishi-Gotanda, Shinagawa-ku, Tokyo, Japan 141-0031
Phone: 81-3-5740-2700
Email: r14525@onsemi.com

ON Semiconductor Website: <http://onsemi.com>

For additional information, please contact your local Sales Representative.